

## U-SERIES

125PS [92kW] acc. to ISO 8665



### 1.6 Liter Compact High Speed Diesel

The U-engine family brings to boating the additional benefits of diesel power which, in the past, were limited to use gasoline engines.

It features a compact package which combines sophisticated common rail electronic fuel injection (CRDi) with the latest generation computer controlled engine management system.

A variable geometry turbocharger (VGT) coupled with the intercooler provides superb acceleration as well as optimal boost at cruise - all while keeping fuel consumption under tight control. Available for inboard, sterndrive and jet applications, whether the need is for new builds or for repower, the U125 is ready to serve.

### Technical Descriptions

#### Engine

- Cast iron engine cylinder block
- Aluminum head
- Oil cooled pistons
- In-line 4, 16-valve DOHC
- Hydraulic lash adjusters
- Integrated water jacket
- Hydraulic timing chain auto tensioner
- Single serpentine belt system
- Drive belt auto tensioner

#### Engine Mounting

- Adjustable engine mounts

#### Lubrication System

- Easily exchangeable oil filter cartridge
- Electric oil extraction pump

#### Turbocharger

- VGT, Variable Geometry Turbocharger

#### Noise Level

- 67.0dB (RCD Standard 75dB)

#### Fuel System

- Common Rail Direct Injection (CRDi)-Solenoid injector
- Fuel filter with sensor detecting water in fuel
- Dual pressure control valve

#### Electrical System

- 12 volt system and 130A alternator
- Auxiliary engine stop button
- Ceramic glow plugs for a trouble-free cold start
- NMEA2000 Converter (Optional)
- Electronic control system (Optional)

#### Cooling System

- V-ribbed belt driven seawater pump
- Seawater cooled intercooler, heat exchanger
- Corrosion resistant material for the seawater circuit
- Easily exchangeable rubber impeller

#### Air Inlet system

- Reusable air filter
- Crankcase gases vented into the air inlet
- Intake silencer (Optional)

#### Engine Operation Indicator (EOI)



- Engine self protection and diagnosis
- Displays CAN information
- Displays engine diagnostic error codes
- Audible alarm and control lamps

#### Exhaust System

- Engine coolant cooled exhaust manifold
- Seawater cooled exhaust elbow

#### Engine Coupler

- Life-long and rattle free rubber roller coupler

#### Emissions

- BSO and RCD compliant

### Scope of Supply

#### 1. RATINGS

S4	SPECIAL PLEASURE DUTY SPECIAL LIGHT DUTY COMMERCIAL
S5	PLEASURE DUTY

#### 2. GAUGES

KEY SWITCH ASSEMBLY, TACHOMETER, COOLANT TEMPERATURE, VOLTMETER and TRIM GAUGE FOR STERNDRIVE

\* Factory-installed option,  
\*\*\* Supply schedule may differ.  
To find out more about configurations and accessories available, please contact your nearest Hyundai SeasAll network.

		RATINGS 1	OPERATION MANUAL	EOI (Engine Operation Indicator)	SeasLink ***	GAUGES 2	COUPLER	ENGINE OIL EXTRACTION PUMP	SEA WATER PUMP *	POWER STEERING PUMP *	BEARING HOUSING PUMP *	EXHAUST ELBOW USING ASSEMBLY *	EXHAUST PIPE (FOR STERNDRIVE)	TWO-POLE (INSULATED SYSTEM) *	INTAKE SILENCER	INSTRUMENT PANEL	NMEA2000 CONVERTER	ELEC. CONTROL SYSTEM	MECH. CONTROL SYSTEM	STEERING WHEEL	SAFETY STOP SWITCH	MECH. CONTROL CABLE	HELMHOLD 90° BEZEL CABLE	SS PROP
U125S	S5,S4	●	●	●	●	●	●	●	●	●	●	●	●	●	●	●	●	●	●	●	●	●	●	●
U125S-BRAVO 1X	S5,S4	●	●	●	●	●	●	●	●	●	●	●	●	●	●	●	●	●	●	●	●	●	●	●
U125P	S5,S4	●	●	●	●	●	●	●	●	●	●	●	●	●	●	●	●	●	●	●	●	●	●	●
U125P-ZF45A	S5,S4	●	●	●	●	●	●	●	●	●	●	●	●	●	●	●	●	●	●	●	●	●	●	●
U125J	S5,S4	●	●	●	●	●	○	○	○	○	○	○	○	○	○	○	○	○	○	○	○	○	○	○
U125J-ZF45C	S5,S4	●	●	●	●	●	○	○	○	○	○	○	○	○	○	○	○	○	○	○	○	○	○	○

● : Standard / ○ : Option / - : N/A / S = Sterndrive / P = Propeller Shaft / J = Water Jet

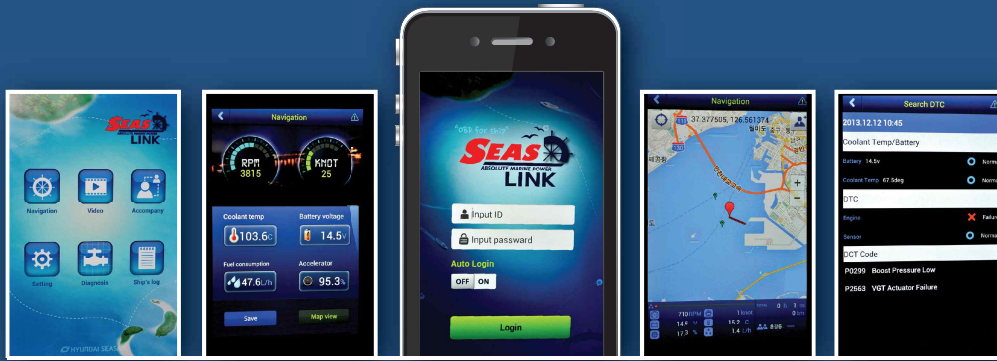

**SEAS LINK**  
ABSOLUTE MARINE POWER

### ON THE SMARTER PHONE

- Displays Engine Information
- Displays Boat Track on the Map
- Monthly User's Log Information
- Engine Diagnostic Functions
- Audible Warning Alarm and Visual Pop-up Screen



## Specifications

Engine type	U125S	U125P	U125J
Propulsion system	Sterndrive	Shaftdrive	Waterjet
Engine Duty Rating	Pleasure Duty (S5) Special Pleasure Duty, Special Light Duty Commercial (S4)		
Configuration	4-Stroke, 16-Valve DOHC, VGT with Intercooler, Fresh Water Cooling		
Output [PS (kW)]	125 (93)		
Rated rpm	4,000		
Cylinders	In-line 4		
Displacement [cc]	1,582		
Bore X Stroke [mm]	77.2 X 84.5		
Max. Torque @ rpm	26.3kg·m @2,000rpm		23.5kg·m @3,700rpm
Injection System	Common Rail Direct injection (CRDi) - Solenoid Injector		
Alternator	12V-130A		
Engine Diagnostics	YES		
Fuel Consump.[L/h]	27		
Dry Weight [kg]	220		
Flywheel	SAE6.5		
Flywheel Housing (P/J type)	Borgwarner Flange		

## Dimensions

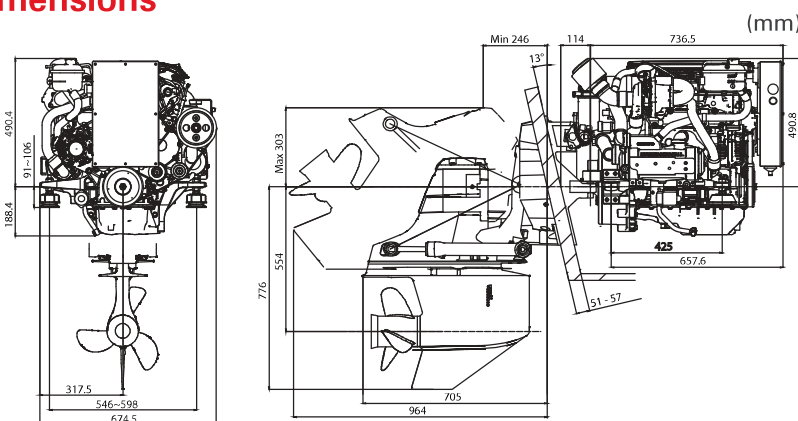

U125S Bravo One X Diesel

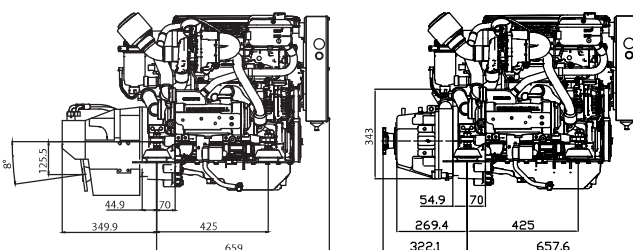

U125P ZF 45A

U125J ZF 45C

## Performance Curves

### U125S | U125P Performance Curves

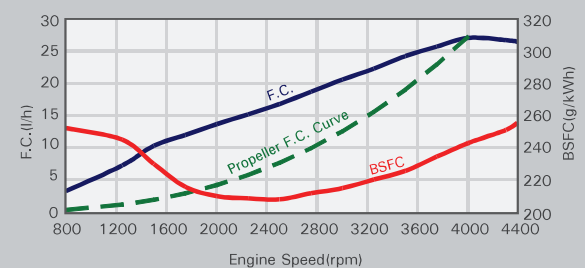
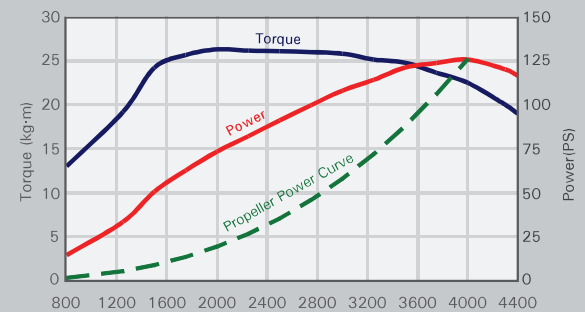

### U125J Performance Curves

