

# H-SERIES

380PS [280kW] acc. to ISO 8665



This modern, electronically controlled design delivers 380PS and 170kg-m of torque from the 10 liter in-line 6 cylinder engine.

The broad flat torque curve proves Hyundai SeasAll's diesel development capabilities are world-class and beats performance of competition's comparable models.

Economy is assured by the state-of-the-art fuel management system featuring Electronic Unit Injectors(EUI). The electronic engine control system makes the engine lighter, quieter and more fuel efficient with excellent compact dimensions.

The unique one-piece CGI (Compacted Graphite Iron) cylinder head makes the engine lighter and quieter than conventional heads for more comfort onboard. Plus, longevity is assured with close to double the fatigue life of aluminum.

## Technical Descriptions

### Engine

- 6 cylinder in-line, 24 valve OHC
- One-piece Compacted Graphite Iron (CGI) cylinder head
- Cast iron cylinder block
- Gallery oil-cooled long lasting mono steel pistons
- Integrated water jacket
- Single serpentine belt system
- Drive belt auto tensioner

### Air Inlet system

- Reusable air filter
- Intake Extension Kit(Optional)

### Fuel System

- Electronic Unit Injector (EUI)
- Gear-driven fuel pump
- Electronically controlled injection timing
- Fine fuel filter and water separator

### Electrical System

- 24 volt - 70A alternator
- Auxiliary engine stop button
- Air heating system for a trouble-free cold start
- NMEA2000 Converter (Optional)
- 2 Pole system (Optional)

### Cooling System

- Gear-driven seawater pump
- Seawater-cooled intercooler, heat exchanger
- Auxiliary connector for cabin heating
- Corrosion resistant material for seawater circuit
- Easily accessible seawater impeller pump

### Engine Mounting

- Adjustable engine mounts (Optional)

### Lubrication System

- Easily exchangeable oil filter cartridge
- Integrated oil-cooler in cylinder block
- Closed system with forced feeding
- Eco type oil filter
- Electric oil extraction pump

- Gear drive engine oil pump

### Instrument Box Assembly



- Engine self-protection and diagnosis
- Displays CAN information
- Displays engine diagnostic error codes
- Audible alarm and control lamps
- Idle & PTO rpm adjustable switch

### Exhaust System

- Cast iron exhaust pipe
- E-VGT, Electric Variable Geometry Turbocharger

### Emissions

- IMO NOx (EIAPP) Compliant

### Type Approval

- RINA Classification Society

## Scope of Supply

		RATINGS 1	OPERATION MANUAL	INSTRUMENT BOX ASSEMBLY (WITH EOI)	Seaslink ***	BELT COVER **	EXHAUST PIPE	SEA WATER PUMP	TWO-POLE (INSULATED SYSTEM) *	INTAKE EXTENSION KIT **	NMEA2000 CONVERTER	SAFETY STOP SWITCH
H380P	S1	●	●	●	●	●	○	○	○	○	○	○
H350G	S1	●	●	●	●	●	○	○	○	○	○	○

● : Standard / ○ : Option / P = Propeller Shaft / G = For Generator

### 1. RATINGS

S1 HEAVY DUTY COMMERCIAL

### 3. INSTRUMENT BOX ASSEMBLY includes EOI BOX, RPM GAUGE and WIRING HARNESS

\* Factory-installed option, \*\* Standard or optional depending on market.

\*\*\* Supply schedule may differ.

To find out more about configurations and accessories available, please contact your nearest Hyundai SeasAll network.

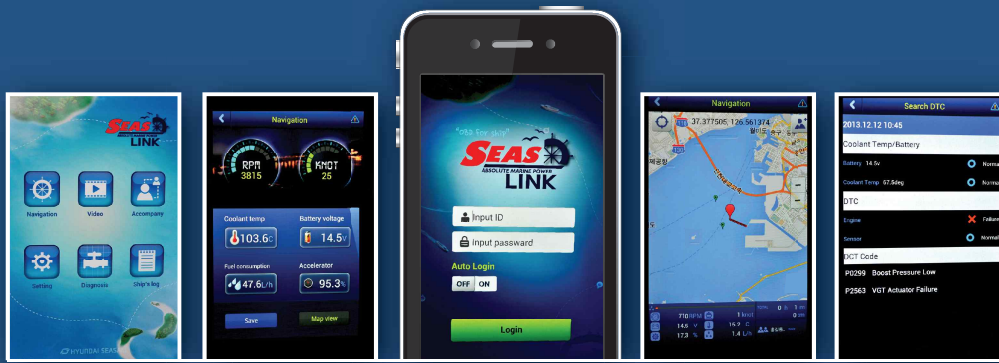

**SEAS LINK**  
ABSOLUTE MARINE POWER

### ON THE SMARTER PHONE

- Displays Engine Information
- Displays Boat Track on the Map
- Monthly User's Log Information
- Engine Diagnostic Functions
- Audible Warning Alarm and Visual Pop-up Screen



## Specifications

Engine type	H380P	H350G
Propulsion system	Shaftdrive	For Generator
Engine Duty Rating	Heavy Duty(S1)	Prime Power
Configuration	4-Stroke, 24-Valve OHC E-VGT with Intercooler, Fresh Water Cooling	
Output [PS (kW)]	380 (280)	350 (257)
Rated rpm	1,800	
Cylinders	In-line 6	
Displacement [cc]	9,960	
Bore X Stroke [mm]	122 X 142	
Compression Ratio	16 : 1	
Max. Torque @ rpm	170kg·m @1,100rpm	-
Injection System	Electronic Unit Injector (EUI)	
Alternator	24V-70A	
Engine Diagnostics	YES	
Fuel Consump.[L/h]	71.0	64.8
Dry Weight [kg]	1,120	
Flywheel	SAE 14	
Flywheel Housing	SAE 1	

## Performance Curves

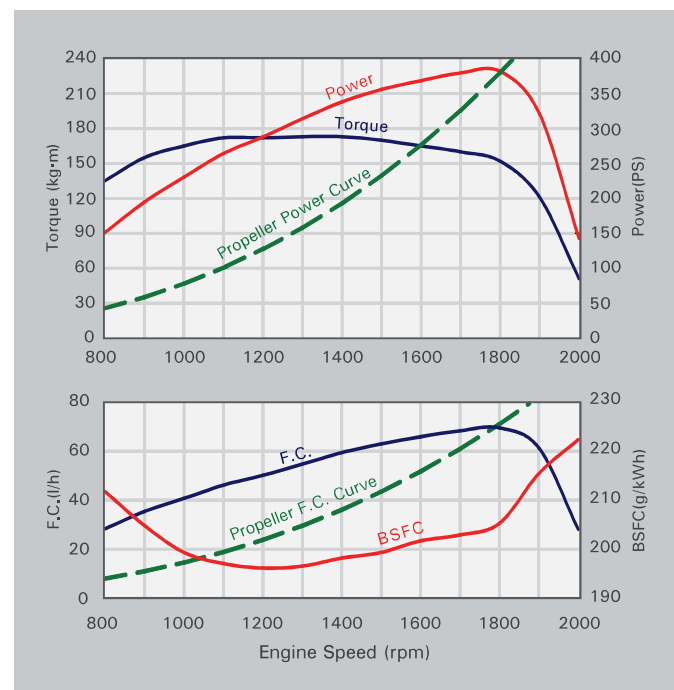

## Dimensions

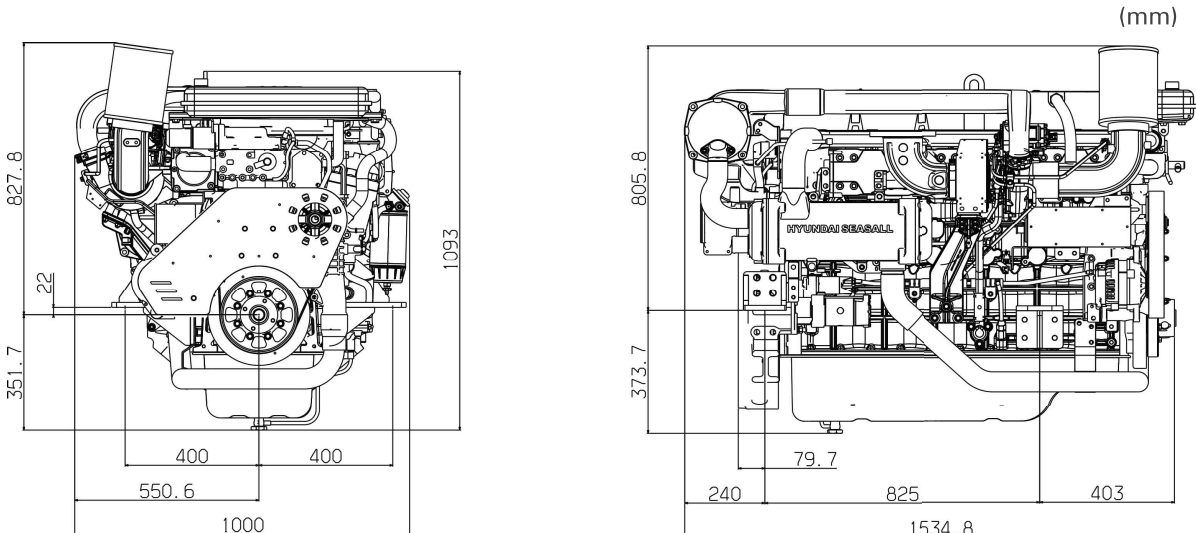

H380